

LINE THERMAL PRINTER

MODEL CT-S310

User's Manual

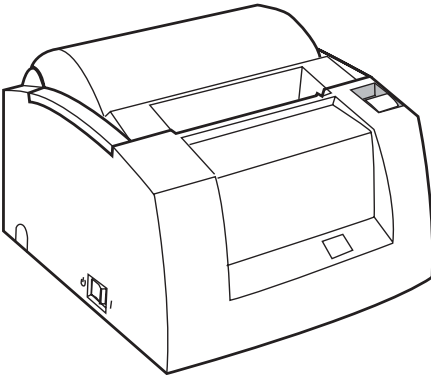

CITIZEN SYSTEMS JAPAN CO., LTD.

Declaration of Conformity

This printer conforms to the following Standards:

Low Voltage Directive 73/23/EEC, 93/68/EEC and the EMC Directive 89/336/EEC, 92/31/EEC, 93/68/EEC.

LVD : EN60950

EMC : EN55022 Class A
EN61000-3-2
EN61000-3-3
EN55024

This declaration is applied only for 230V model.

IMPORTANT: This equipment generates, uses, and can radiate radio frequency energy and if not installed and used in accordance with the instruction manual, may cause interference to radio communications. It has been tested and found to comply with the limits for a Class A computing device pursuant to Subpart J of Part 15 of FCC Rules, which are designed to provide reasonable protection against such interference when operated in a commercial environment. Operation of this equipment in a residential area is likely to cause interference, in which case the user at his own expense will be required to take whatever measures may be necessary to correct the interference.

CAUTION: Use shielded cable for this equipment.

Sicherheitshinweis

Die Steckdose zum Anschluß dieses Druckers muß nahe dem Gerät angebracht und leicht zugänglich sein.

For Uses in Canada

This digital apparatus does not exceed the class A limits for radio noise emissions from digital apparatus, as set out in the radio interference regulations of the Canadian department of communications.

Pour L'utilisateurs Canadiens

Cet appareil numérique ne dépasse pas les limites de catégorie A pour les émissions de bruit radio émanant d'appareils numériques, tel que prévu dans les règlements sur l'interférence radio du département Canadien des communications.

GENERAL PRECAUTIONS

- Before using this product, be sure to read through this manual. After having read this manual, keep it in a safe, readily accessible place for future reference.
- The information contained herein is subject to change without prior notice.
- Reproduction or transfer of part or all of this document in any means is prohibited without permission from CITIZEN SYSTEMS.
- Note that CITIZEN SYSTEMS is not responsible for any operation results regardless of missing, error, or misprinting in this manual.
- Note that CITIZEN SYSTEMS is not responsible for any trouble caused as a result of using options or consumables that are not specified in this manual.
- Except explained elsewhere in this manual, do not attempt to service, disassemble, or repair this product.
- Note that CITIZEN SYSTEMS is not responsible for any damage attributable to incorrect operation/handling or improper operating environments that are not specified in this manual.
- Data are basically for temporary use, not stored for a long period or permanently. Please note that CITIZEN SYSTEMS is not responsible for damage or lost profit resulting from the loss of data caused by accidents, repairs, tests or other occurrence.
- If you find loss of information, error, or uncertain matter, please contact your CITIZEN SYSTEMS dealer.
- If you find any disordered or missing page(s), contact your CITIZEN SYSTEMS dealer for replacement.

SAFETY PRECAUTIONS ... WHICH SHOULD BE STRICTLY OBSERVED

Before using this product for the first time, carefully read these SAFETY PRECAUTIONS. Incorrect operation may result in unexpected accidents (fire, shock, or injury).

- After having read this Manual, keep it in a safe, readily accessible place for future reference.
- Some of the descriptions contained in this manual may not be relevant to some printer models.

In order to prevent injury hazard to operators, third parties or damage to property, special warning symbols are used in this user's manual to indicate important items to be strictly observed.

The following describes the degree of hazard and damage that could occur if the printer is improperly operated by ignoring the instructions indicated by the warning symbols.

WARNING

Neglecting precautions indicated by this symbol may result in fatal or serious injury.

CAUTION

Neglecting precautions indicated by this symbol may result in injury or damage to properties.



This symbol is used to alert your attention to important items.



This symbol is used to alert you to the danger of electric shock or electrostatic damage.



This symbol denotes a request to unplug the printer from the wall outlet.



This symbol is used to indicate the "information" on the use, or the like.



This symbol is used to indicate prohibited actions.

PRECAUTIONS ON PRINTER INSTALLATION

WARNING

Do not use or store this product in a place where it will be exposed to:

- Flames or moist air
- Direct sunlight
- Hot airflow or radiation from a heating device
- Salty air or corrosive gases
- Ill-ventilated atmosphere
- Chemical reactions in a laboratory
- Airborne oil, steel particles, or dust
- Static electricity or strong magnetic field
- **Neglecting these warnings may result in printer failure, overheating, emission of smoke, fire, or electric shock.**



Do not drop any foreign object nor spill liquid into the printer. Do not place any object on the printer either.

- Do not drop any metallic object such as paper clip, pin or screw into the printer.
- Do not place a flower vase, pot or cup containing water on the printer.
- Do not spill coffee, soft drinks or any other liquid into the printer.
- Do not spray insecticide or any other chemical liquid over the printer.
- **A metallic foreign object, if accidentally dropped into the printer, may cause printer failure, fire, or electric shock. Should it occur, immediately turn the printer off, unplug it from the supply outlet, and call your local CITIZEN SYSTEMS dealer.**



Do not handle the printer in the following ways:

- Do not allow the printer to sustain strong impacts or hard jolts (e.g., trampling, dropping, striking with a hard edge).
- Never attempt to disassemble or modify the printer.
- **Neglecting to handle properly may result in printer failure, overheating, emission of smoke, fire, or electric shock.**



Install, use, or store the printer out of the reach of children.

- **Electric appliances could cause an unexpected injury or accident if they are handled or used improperly.**
- **Keep the power cord and signal cables out of the reach of children. Also children should not be allowed to gain access to any internal part of the printer.**
- **The plastic bag the printer came in must be disposed of properly or kept away from children. Wearing it over the head may lead to suffocation.**



CAUTION

Place the printer on a flat, stable surface without vibration.

- **Otherwise dropping may cause injury.**



Do not use the printer under the following conditions.

- A state where the printer ventilation holes are blocked by a nearby wall or something
- A state where any object is placed on the printer
- A state where the printer is covered or wrapped by a cloth or bed clothing
- **Be careful about internal heat buildup, which could cause fire and deform the case.**
- Avoid using the printer near a radio or TV set or from supplying it from the same outlet as these appliances.
- Avoid using the printer interconnected with a cable or cord that has no protection against noise. (For interconnections, use shielded or a twisted pair of cables and ferrite cores, or other anti-noise devices.)
- Avoid using the printer with a device that is a strong source of noise.
- **The printer may have an adverse effect on nearby radio or TV transmissions. There may also be cases when nearby electrical appliances adversely influence the printer, causing data errors or malfunction.**



Use the printer with its grounding post connected to a convenient grounding facility.

- **If leakage occurs electric shock may result.**



Do not connect the printer's grounding post onto any of the following facilities.

- Utility gas piping
A gas explosion could result
- Telephone line ground
- Lightning rod
If lightning strikes a large surge of current may cause fire or shock.
- Utility water pipes
Plastic water pipes should not be used for grounding. (Those approved by a Waterworks Department may be used.)



Before connecting or disconnecting the grounding lead to or from the printer, always unplug it from supply outlet.

PRECAUTIONS IN HANDLING THE PRINTER

WARNING

Please observe the following precautions for power source and power cord:

- Do not plug or unplug the power cord with a wet hand.
- Use the printer only at the specified supply voltage and frequency.
- Use only the specified AC adapter with the printer.
- Use the power cord supplied with the product. Never use the power cord for other product.
- Check to make sure that the supply outlet from which the printer is powered has a sufficient capacity.
- Do not supply the printer from a power strip or current tap shared with other appliances.
- Do not plug the power cord into a supply outlet with dust or debris left on its plug.
- Do not use a deformed or damaged power cord.
- Do not move the printer while the printer power is on.
- **Neglecting to handle properly may result in printer failure, emission of smoke, fire, or electric shock.**
- **An overload may cause the power cord to overheat or fire or the circuit breaker to trip.**
- Do not allow anything to rest on the power cord. Do not place the printer where the power cord will be trampled on.
- Do not use or carry the printer with its power cord bent, twisted, or pulled.
- Do not attempt to modify the power cord unnecessarily.
- Do not lay the power cord in the neighbor of a heating device.
- **Neglecting these cautions may cause wires or insulation to break, which could result in leakage, electric shock, or printer failure. If a power cord sustains damage contact your CITIZEN SYSTEMS dealer.**
- Do not leave things around the supply outlet.
- Supply power to the printer from a convenient wall outlet, readily accessible in an emergency.
- **The printer may not be immediately shut down in an emergency.**
- Insert the power plug fully into the outlet.
- If the printer is not to be used for a long time, leave it disconnected from its supply outlet.
- Hold the plug and connector when plugging or unplugging the power cord or signal cable after turning off the printer and the appliance connected to it.



CAUTION

Caution label is attached on the position shown in the following figure. Carefully read the precautions in handling before using the printer.

THIS LABEL INDICATES THE RISK OF ANY INJURY DUE TO "HIGH TEMPERATURE" OF THE PRINT HEAD.

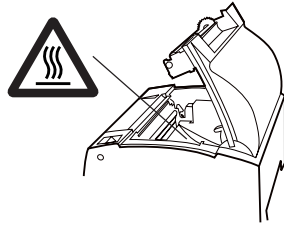

To prevent possible malfunction or failure observe the following.

- Avoid operating the printer without paper properly loaded.
- Avoid the use of paper not complying with specifications.
 - **May result in poor print quality.**
- Avoid using torn pieces of paper or spliced with plastic adhesive tapes.
- Avoid forcibly pulling already loaded paper by hand.
- Avoid wedging the paper in by the paper cover.
 - **May jam paper. To release, refer to "Removing Jammed Paper" in this manual.**
- Avoid using a sharp pointed device to operate panel keys.

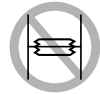

Be sure to firmly insert the cable plug into its mating socket.

- **A cross connection may damage the printer's internal electronics or the host system's hardware.**

Only use the printer with devices that have designated solenoid specifications for the cash drawer interface connector.

- **Neglecting this caution may result in malfunction or failure.**



To prevent injury and printer failures from worsening, observe the following:

- Do not touch the printing surface of the thermal head.
- Do not touch any of the moving parts (e.g., paper cutter, gears, active electrical parts) while the printer is working.
- In case of trouble do not attempt to repair the printer. Ask CITIZEN SYSTEMS service for repair.
- Be careful that the paper cover does not entrap your hands or fingers.
- Be careful with sharp edges on the printer. Don't allow them to injure you or damage property.
- **May result in electric shock, burn, or injury.**
- **If the printer emits smoke, an odd smell, or unusual noise while printing, immediately abort the current print session and unplug the printer from the supply outlet.**



DAILY MAINTENANCE

Observe the following precautions for daily maintenance.

- When cleaning the printer, always turn it off and unplug it from the supply outlet.
- Use a soft, dry cloth for cleaning the surface of the printer case.
- For severe stains, use a soft cloth slightly dampened with water.
- Never use organic cleaning solvent such as alcohol, paint thinner, trichloroethylene, benzene, or ketone. Never use a chemically processed cleaning cloth.
- To remove paper chips, use a soft brush.
- When transporting the printer, remove the roll paper from its paper holder.



CAUTION

- **The thermal head is at a dangerously high temperature immediately after printing. Allow it to cool off before launching maintenance work.**

THE TABLE OF CONTENTS

1. GENERAL OUTLINE	9
1.1 Features	9
1.2 Unpacking	10
1.3 Model Classification	10
1.4 Basic Specifications	11
2. EXPLANATION OF PRINTER PARTS	12
2.1 Printer Appearance	12
2.2 Paper Cover Inside	14
2.3 Other Built-in Functions	14
3. PREPARATION	15
3.1 Connecting the AC Adapter and AC Power Cord	15
3.2 Connecting Interface Cables	16
3.3 Connecting the Cash Drawer	17
3.4 Installing the Printer	18
3.5 Partition for 58-mm Wide Paper Roll	18
3.6 Setting DIP Switch	19
3.7 Adjusting the Paper Near-end Sensor	20
4. MAINTENANCE AND TROUBLESHOOTING	21
4.1 Setting/Replacing Paper Rolls	21
4.2 Removing Jammed Paper	21
4.3 Cleaning the Print Head	22
4.4 When the Paper Cover Cannot Be Opened	22
4.5 Self-printing	23
4.6 Hexadecimal Dump Printing	23
4.7 Error Indication	24
5. OTHER	25
5.1 External Views and Dimensions	25
5.2 Manual Setting of Memory Switch	26
5.3 Printing Paper	28

1. GENERAL OUTLINE

The CT-S310 is a thermal line printer designed for use with a broad array of terminal equipment including, data, POS, and kitchen terminals. With extensive features, it can be used in a wide range of applications.

1.1 Features

- Compact design.
- Paper drop-in mechanism facilitating paper handling and head cleaning.
- High speed (150 mm/s) printing.
- Low-noise printing.
- Built-in input buffer.
- Barcode printing.
- Page mode. Now you can arrange pages freely.
- Registration of user-defined characters and logos into flash memory.
- Built-in cash drawer interface.
- Auto cutter mechanism provided as a standard unit (full cut/partial cut).
- Can use 80 mm or 58 mm wide paper roll.
- Equipped with USB interface as standard.
- Replaceable interface board.
- A variety of functions selectable with memory switch.
- The printer allows horizontal, vertical, or wall-mounted (optional) installation.
- Built-in buzzer.
- Two types of power supply. Select between built-in power supply type and AC adapter type.
- Various kinds of customization are permitted.
- 2-color printing is supported.

1.2 Unpacking

When unpacking the printer, confirm that the following are provided:

- Printer: 1
- AC adapter (AC adapter type): 1
- AC power cord: 1
- Sample paper roll: 1 roll
- Partition for 58-mm wide paper roll: 1
- User's manual (This manual): 1

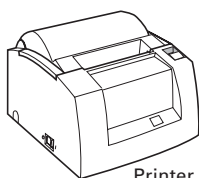

Printer
(AC adapter type)

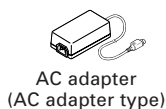

AC adapter
(AC adapter type)



Partition for 58-mm
wide paper roll



Printer
(Built-in power supply type)

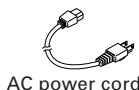

AC power cord



Sample paper roll

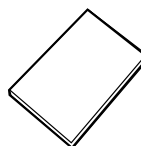

User's manual
(This manual)

1.3 Model Classification

The printer models are classified by the following designation method:

CT - S310 A RS U - BK - M1

Power supply
No marking: AC power type
(built-in power supply)
DC: DC power supply type

Interface
RS: Serial RS-232C compliant
PA: Parallel IEEE 1284 compliant
UB: USB

Black mark sensor for back side
None: No sensor
M1: Left black mark sensor
M2: Right black mark sensor

Body case color
WH: Cool white
BK: Black

Inducing ground(Character+AC power cord)
J: Japan
E: Europe
U: North America

1.4 Basic Specifications

Item	Specifications	
Model (Refer to 1.3 Model Classification)	CT-S310ARSU CT-S310APAU CT-S310AUBU	CT-S310ARSE CT-S310APAE CT-S310AUBE
Print method	Line thermal dot print method	
Print width	72 mm/576 dots, (48 mm/384 dots) *1	
Dot density	8 × 8 dots/mm (203 dpi)	
Print speed	150 mm/s (Fastest, print density level 0), 1200 dot lines/s	
Number of print columns *2 () shows the value with 58 mm wide paper.	Font A: 48/42 (32/30) columns; 12 × 24 dots Font B: 64/56 (42/40) columns; 9 × 17 dots Font C: 72/63 (48/45) columns; 8 × 16 dots	
Character size	Font A: 1.50 × 3.00 mm Font B: 1.13 × 2.13 mm Font C: 1.00 × 2.00 mm	
Character type	Alphanumeric, International, PC850/852/857/858/860/863/864/ 865/866/WPC1252/Katakana/Thai code 18	
User memory	256 KB (Capable of registering user-defined characters and logos)	
Types of bar code	UPC-A/E, JAN (EAN) 13/8 columns, ITF, CODE 39, CODE 128, CODABAR, CODE 93	
Line spacing	4.23 mm (1/6 inch)	
Paper roll	Thermal paper roll: 80 ⁺⁰ ₋₁ mm/58 ⁺⁰ ₋₁ mm × φ83 mm Paper thickness: 65-75 μm	
Interfacing	Serial (RS-232C compliant), Parallel (IEEE 1284 compliant), USB	
Cash drawer interface	2 cash drawers are supported.	
Input buffer	Serial 4K/45 bytes, Parallel 4K bytes, USB 4K bytes	
Supply voltage	DC 24 V ±7%	
Power consumption	Approx. 70 W (in normal printing)	
AC adapter	Rated input: AC 100 to 240 V, 50/60 Hz, 150 VA Rated output: DC 24 V, 2A 35AD2-U 35AD2-E	
Weight	Approx. 1.2 kg	
Outside dimensions	145 (W) × 195 (D) × 121 (H) mm (AC Adapter Type) 145 (W) × 195 (D) × 159 (H) mm (Built-in Power Supply Type)	
Operating temperature and humidity	5 to 40°C, 35 to 85% RH (No condensation)	
Storage temperature and humidity	-20 to 60°C, 10 to 90% RH (No condensation)	
Reliability	Print head life: 100 km, 1 × 10 ⁸ pulses (At normal temperature/ humidity with recommended paper used) Auto cutter life: 1 million cuts (At normal temperature/ humidity with recommended paper used)	
Safety standard *3	UL, C-UL, FCC Class A	TUV, GS, CE marking

Notes:

*1: Value in parentheses shows the case when a 58-mm wide paper roll is used.

*2: The number of printable columns is selectable with a DIP switch.

*3: Represents the safety standards acquired when CITIZEN SYSTEMS-made adapters (35AD2 series) are used.

2. EXPLANATION OF PRINTER PARTS

2.1 Printer Appearance

AC Adapter Type

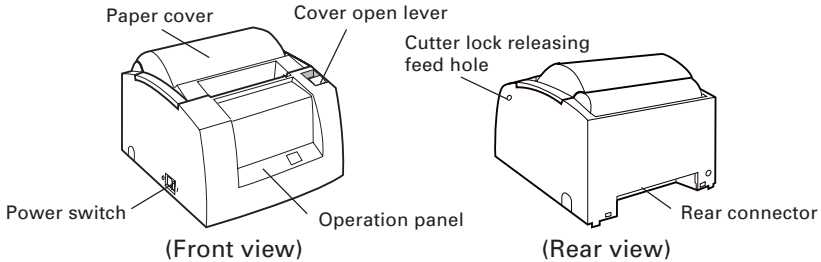

Built-in Power Supply Type

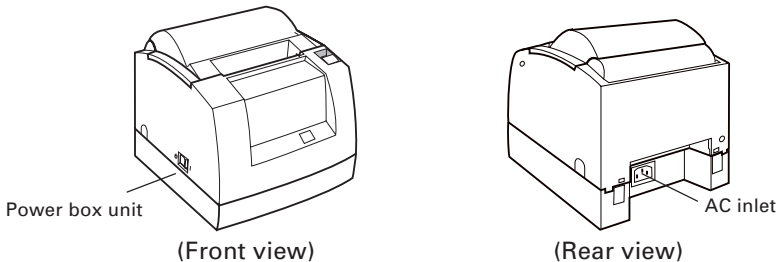

- **Paper cover**
Paper is located inside this cover.
- **Cover open lever**
To refill or replace paper, open the paper cover by pulling this lever fully to the root.
- **Power switch**
This switch turns the printer power ON/OFF.
- **Cutter lock releasing feed hole**
When the cutter blade is kept protruded after abnormal termination or paper jam, the paper cover cannot be opened. Insert a Phillips screwdriver through this hole and adjust the screw to restore the blade.
- **AC inlet (Built-in power supply type)**
Connects to AC cable.

Operation Panel

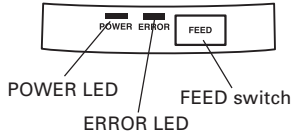

● POWER LED

Lights when the printer power is on and goes off when the printer power is off. May blink or light in a special mode or in case of a failure.

● ERROR LED

Lights or blinks when paper is empty or in case of a failure. The interval length of blinking shows the type of error.

● FEED switch

Pressing this switch once causes a paper feed of one line. The longer the switch is pressed, the more the paper is fed. In case of auto cutter error, press the FEED switch after removing the cause of the error to clear the error.

Rear Connectors

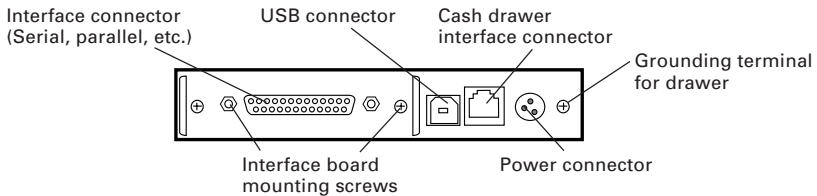

● Interface connector (Serial, parallel, etc.)

Connects to the interface cable. A DIP switch is provided on the serial interface board.

● Cash drawer interface connector

Connects to the cable from the cash drawer.

● Power connector

Connects to the cable from AC adapter.

2.2 Paper Cover Inside

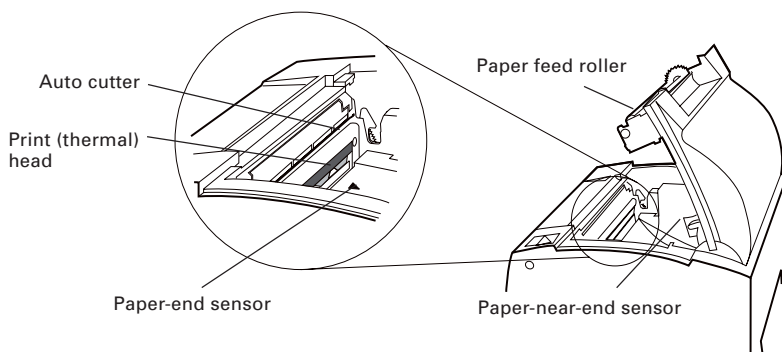

- **Paper feed roller**
Feeds paper as part of print mechanism.
- **Paper-near-end sensor**
Changes the setting in accordance with the inner diameter of paper roll or setting status.
- **Auto cutter**
Cuts the paper with a command at the end of printing. Cutting method is selectable between partial cut and full cut with a command.
- **Print (thermal) head**
Prints characters and/or graphic data on thermal paper.
- **Paper-end sensor**
Stops printing when this sensor detects paper end.

2.3 Other Built-in Functions

- **Buzzer**
This printer has a built-in buzzer. It is operated in case of an error, operation, or by a command.
- **User memory**
Allows registration of user-defined characters and logo data on the nonvolatile memory. Data registered remains even after the printer power is off.
- **Memory switch**
Setting of various kinds of functions can be registered on nonvolatile memory. The setting registered is valid even if the printer power is turned off. In additional memory switch setting can be changed by manual operation.

3. PREPARATION

3.1 Connecting the AC Adapter and AC Power Cord

1. Turn off the printer power.
2. For the AC adapter type only: With the flat side of the AC adapter's cable connector facing upward, insert the cable connector into the power connector on the back side of the printer.
3. Connect the AC power cord to the inlet of the printer, and insert the AC power-cord plug into a suitable wall outlet.

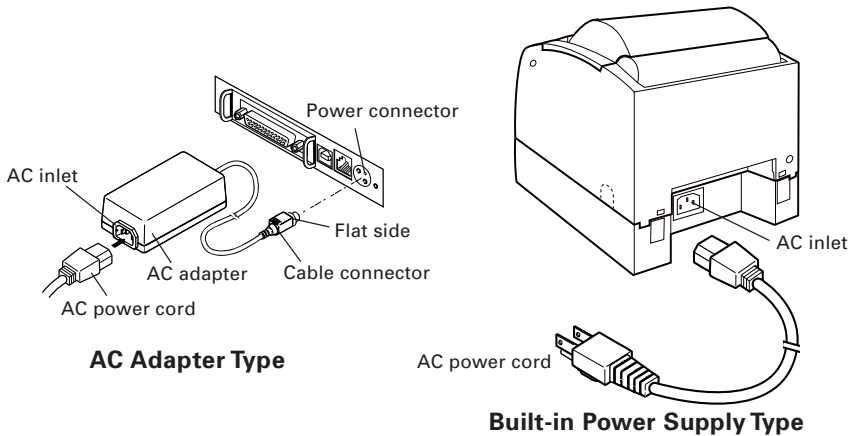

CAUTION!

- Use only the specified AC adapter with the printer.
- When disconnecting a cable, do not pull out by the cable. Always hold the plug.
- Always keep the AC power supply away from other noise generating equipment.
- Do not pull the power cord. Otherwise fire, electric shock, or power disconnection may result.
- If lightning is approaching, unplug the AC power cord from the wall outlet. Otherwise fire or electric shock may result.
- Keep the power cord away from heat generating appliances. Otherwise the shield of power cord may be fused resulting in a fire or electric shock.
- If the printer is not to be used for a long time, leave it disconnected from its supply outlet.

3.2 Connecting Interface Cables

Turn off the printer power and unplug the power connector. Then follow the procedure for interface cable connection.

Orient the interface cable terminal correctly and insert it into the interface connector.

In case of a built-in power supply type, remove the power box unit before connection.

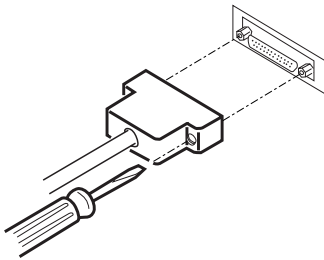

Serial Interface

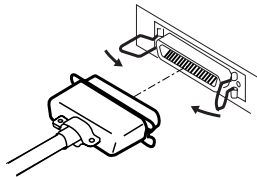

Parallel Interface

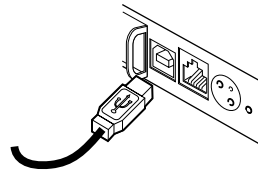

USB Interface

CAUTION!

When disconnecting the cable, always hold the connector.

For serial interface cable, the following connection is recommended.

25-pin - 25-pin cable

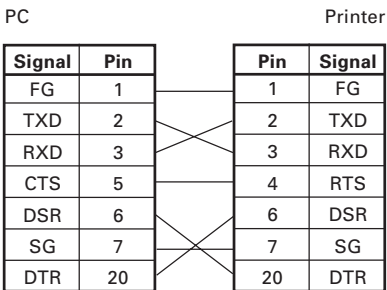

9-pin - 25-pin cable

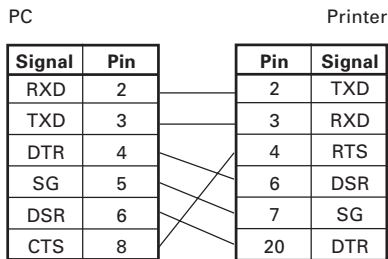

3.3 Connecting the Cash Drawer

1. Turn off the printer power.
2. Orient the cash drawer cable connector correctly, insert it into the cash drawer interface connector on the back of the printer.
3. Connect the drawer's ground line to the printer's ground terminal with a screw. For built-in power type, remove the power box unit before connection.

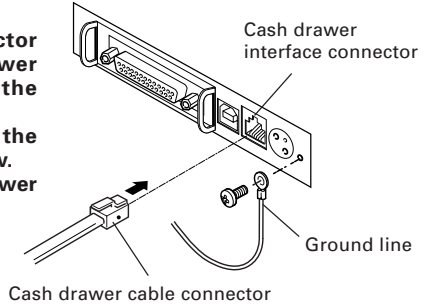

CAUTION!

Do not connect any other device than the specified cash drawer to the cash drawer interface connector. (Do not connect a telephone line either.)

In case of a built-in power supply type, remove the power box unit before connection.

(1) Connector Pin Configuration

No.	Signal	Function
1	FG	Frame Ground
2	DRAWER 1	Drawer 1 drive signal
3	DRSW	Drawer switch input
4	VDR	Drawer drive power supply
5	DRAWER 2	Drawer 2 drive signal
6	GND	Common ground on circuits

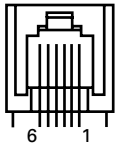

Connector used:
TM5RJ3-66 (Hirose)
or equivalent
Applicable connector:
TM3P-66P (Hirose) or
equivalent

(2) Electrical characteristics

- 1) Driving voltage: 24 VDC
- 2) Driving current: Approx. 1A max. (shall not exceed 510 ms.)
- 3) DRSW signal: Signal levels: "L" = 0 to 0.5 V, "H" = 3 to 5 V

(3) DRSW signal

DRSW signal status can be tested with the DLE+EOT, GS+a, or GS+r command or at pin 34 on the parallel interface port.

(4) Drive Circuit (printer side)

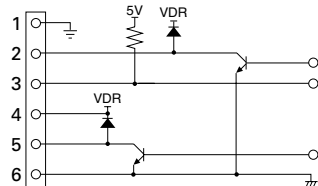

CAUTION!

- No output is produced while printing.
- The cash drawers 1 and 2 cannot be driven simultaneously.
- A solenoid used for the cash drawer should be of 24 Ω or more. The output current should be kept at 1A or less; otherwise, breakdown or burning could occur.

3.4 Installing the Printer

The printer can be installed horizontally, vertically, and on the wall. At the time of shipment, the printer is set for horizontal installation. To install the printer vertically or on the wall, the following adjustments are required.

1. Adjustment of paper near-end sensor position (See section 3.7)
2. Anti-slip rubber feet (for vertical setting)
3. Optional wall-mounting kit (for wall-mounting)
4. Optional right-angle AC cable (when installing the printer with built-in power supply vertically)

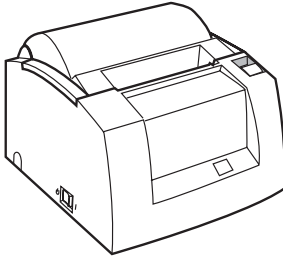

Horizontal position

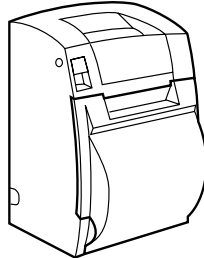

Vertical position



CAUTION!

- When used in vertical position, the printer ejects paper not to fall naturally even with full cutting. Be careful in using the printer built in equipment, etc.
- When using in horizontal setting, avoid cutting full. Otherwise, the cut paper may drop into the cutter and may result in double cutting and narrow pieces of paper. This may cause paper jam.

3.5 Partition for 58-mm Wide Paper Roll

1. Turn off the printer power.
2. Open the paper cover.
3. Attach the "Partition" supplied with the printer to the position shown in the figure.
4. Referring to the section of memory switch setting change the paper width setting to 58 mm.

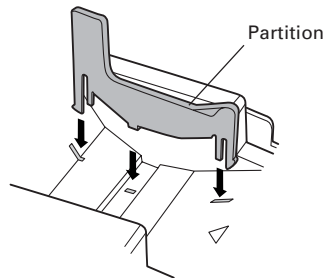

CAUTION!

When using the 58-mm wide paper always use the printer with 58 mm paper only.

3.6 Setting DIP Switch

The DIP switch is present on the serial interface.

Remove the board fixing screws, take out the interface board, and then set the DIP switch.

The function of each switch is as shown below.

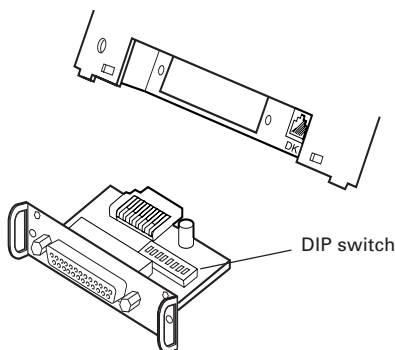

Switch No.	Function	ON	OFF	Initial Settings
1	Communication condition setting method	DIP switch setting	Memory switch setting	OFF
2	Hand shake	XON/XOFF	DTR/DSR	OFF
3	Bit length	7 bits	8 bits	OFF
4	Parity check	With parity	None	OFF
5	Parity selection	Even parity	Odd parity	OFF
6	Baud rate selection	See Table below.		ON
7				ON
8	INIT	Reset	Invalid	OFF

Selecting baud rate

Baud Rate (bps)	Switch No.	
	6	7
2400	OFF	OFF
4800	ON	OFF
9600	OFF	ON
19200	ON	ON

38400 bps can also be selected by memory switches, etc.

3.7 Adjusting the Paper Near-end Sensor

1. Push in the paper near-end sensor unit.
2. Move the paper near-end sensor unit to the right and left while pushing it. The position to be set varies in accordance with the setting of the printer, horizontal or vertical, or the diameter of the paper roll as shown in the following figure.

Sensor Position	Installation Method	Paper Roll External Diameter (mm)
1	Horizontal	$\phi 22$
2		$\phi 24$
3		$\phi 27$
3	Vertical (Wall-mounted)	$\phi 22$
2		$\phi 24$
1		$\phi 27$

CAUTION!

- Paper remainder (outside diameter of roll) differs by the type of paper roll used.
- The external diameter of the paper roll is only for reference.
- Recommended outer diameter of paper roll core is $\phi 18$. If, however, using a paper roll with a diameter of $\phi 22$ is unavoidable, adjustments to "1" for horizontal positioning and "3" for vertical positioning cannot be used.

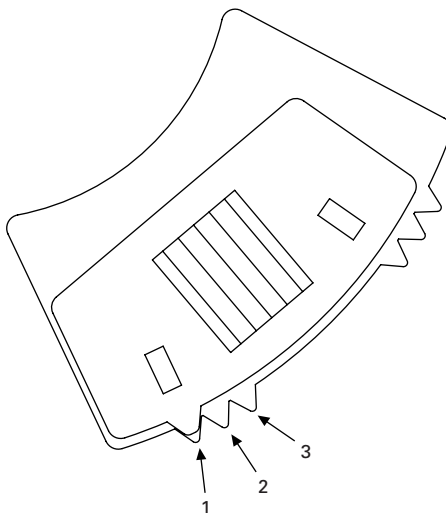

4. MAINTENANCE AND TROUBLESHOOTING

4.1 Setting/Replacing Paper Rolls

1. Pull the cover open lever fully toward you.
2. Open the paper cover.
3. Insert a paper roll with its print area facing down as shown in the figure and pull out the paper end straightforward by several cm out of the printer.
4. Close the paper cover until a click can be heard.

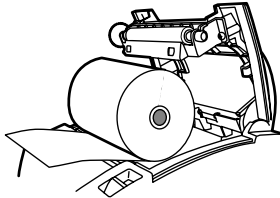

CAUTION!

- Always use the specified types of paper roll.
- Confirm that the paper roll is set correctly.
- When the paper is skewed and not extended straightforward from under the cover, open the cover and adjust the paper correctly.
- When closing the cover, press on the center part of the cover to close it firmly.



WARNING

When opening the paper cover, take care not to touch the print head or cutter blade. Otherwise, burning or injury of hand may result.

4.2 Removing Jammed Paper

1. Turn the printer power off.
2. Open the paper cover.
If the cutter blade remains protruded with paper jammed, do not open the paper cover forcibly. Referring to section 4.4, restore the blade to the normal position and then open the cover.
3. Remove the jammed paper including any paper chips remaining. (Also take out the paper roll from the holder.)
4. Turn on the printer. The auto cutter mechanism is initialized and the alarm is cleared.



CAUTION!

The print head is hot immediately after printing. Do not touch it with your hand. Do not touch the heating element of the head with a bare hand or metal object either.

4.3 Cleaning the Print Head

1. Turn the printer power off.
2. Open the paper cover.
3. Wait several minutes. Wipe off any debris on the heating element of the head using a cotton swab soaked in ethyl alcohol.

CAUTION!

The print head is hot immediately after printing. Do not touch it with your hand. Do not touch the heating element of the head with a bare hand or metal object either.

4.4 When the Paper Cover Cannot Be Opened

If the cutter blade remains protruded due to paper jam or for any abnormality, opening the paper cover may be disabled.

In this case, do not open the paper cover forcibly. Insert a Phillips screwdriver into the cutter lock releasing feed hole and turn it in the direction of arrow (clockwise).

Use a #1 screwdriver.

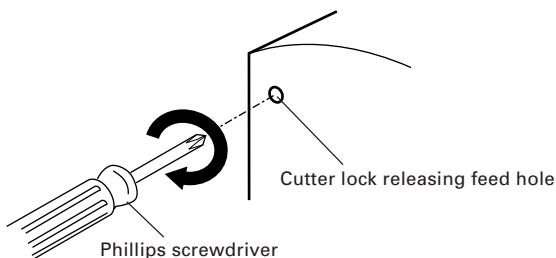

When you find that both ends of the blade reached the lowest position, stop turning the screwdriver. Open the cover and follow the procedure of removing jam or other cause of trouble.

4.5 Self-printing

Insert paper into the printer. With the FEED switch pressed and held, turn the printer power on, keep the FEED switch held for about 1 second, and then release the FEED switch. The printer starts self-printing. The printer prints model name, version, DIP switch setting, memory switch setting, and built-in fonts.

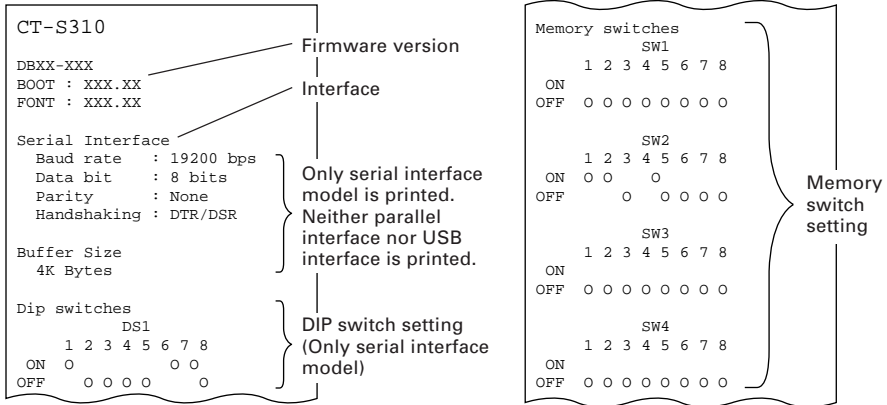

4.6 Hexadecimal Dump Printing

This function is to print all received data in hexadecimal numbers. If problems such as missing data, data duplication, etc. should occur, this function allows checking whether or not the printer is receiving data correctly.

Set paper to the printer and keep the paper cover open. With the FEED switch pressed and held, turn the printer power on and then close the paper cover. The printer prints "HEX dump print mode" followed by the received data printed in hexadecimal numbers and some characters.

CAUTION!

- The printer prints "." if there is no characters corresponding to data.
- During hexadecimal dump, functions except some command will be disabled.
- If print data does not cover a line, press the FEED switch to print the line.

When you press the FEED switch three times consecutively, or you turn the printer power off, or the printer receives a reset signal from the interface, the hexadecimal dump printing is terminated.

Print example









```

HEX DUMP PRINT MODE
1B 21 00 1B 20 04 41 42 43 44 !.. .ABCD
45 46 47 48 49 4A 4B 4C 4D 4E EFGHIJKLMN
4F 50 0D 0A 31 32 33 0D 0A OP..123..
  
```

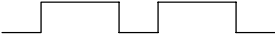
4.7 Error Indication

- Paper end
Paper empty is detected in two steps: paper near-end and paper end. It causes the ERROR lamp to light. If paper end is detected, refill the paper. If the paper cover is open, a paper-end is detected.
- Paper cover open
During printing, do not open the paper cover. If you open the paper cover accidentally, the ERROR lamp blinks. Confirm the paper and close the over. Printing resumes automatically.
- Thermal head overheating
When you print dense characters or dark image, the head temperature rises. If the head temperature exceeds a specified level, the printer stops printing operation and waits till the head temperature is lowered. During waiting, the ERROR lamp blinks. When the head temperature is lowered, printing resumes automatically.
- Cutter lock
If the cutter blade stops operating due to paper jam or the like, the ERROR lamp blinks. Remove the cause of the trouble and press the FEED switch. If the blade does not move and the cover does not open yet even in the above procedure, follow the procedure in section 4.4 to open the paper cover.
- Black Mark detection error (in Black Mark mode)
When no Black Mark can be detected even if a certain amount of paper feed is carried out for Black mark detection, a Black Mark detection error occurs. If black detection continues more than the specified period, a No Paper condition is assumed and the same error as No Paper is indicated.

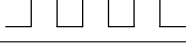
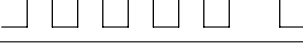
Lighting and blinking status of each error including the above is shown below.

Status	POWER Lamp	ERROR Lamp	Buzzer
Paper-end	Lights	Lights	○
Paper near-end	Lights	Lights	
Cover open error	Lights	Light	○
Cover open error *1	Lights		○
Cutter lock error	Lights		○
Head overheating error	Lights		
Memory check error		Turning off	
Low voltage error	Lights		
High voltage error	Lights		
Sum check error			
Macro execution wait *2	Lights		
Black Mark detection error	Lights		○

*1: When the printer is printing.

*2: The ERROR lamp may blink even in the execution of macro function.

5. OTHER

5.1 External Views and Dimensions

(Unit: millimeter)

AC Adapter Type

Built-in Power Supply Type

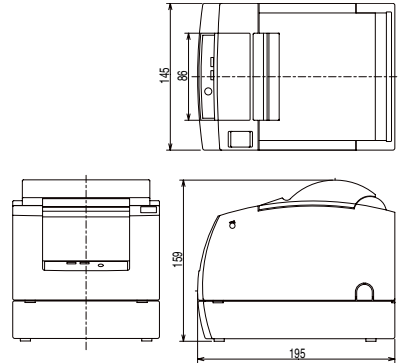
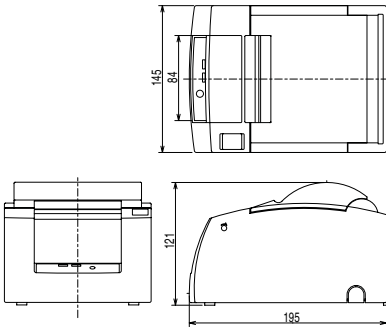

5.2 Manual Setting of Memory Switch

Memory switches can be set manually or by a command.

For manual setting, refer to the next page.

The function of each memory switch is shown in the following table.

(The **white-on-black characters** are factory setting.)

Switch No.	Setting	0 (OFF)	1 (ON)
Memory SW1-1	Power ON Info	Valid	Not send
SW1-2	Buffer Size	4K bytes	45 bytes
SW1-3	Busy Condition	Full/Err	Full
SW1-4	Receive Error	Print ?	No Print
SW1-5	CR mode	Ignored	LF
SW1-6	Reserved	Fixed	-
SW1-7	DSR Signal	Invalid	Valid
SW1-8	Init Signal	Invalid	Valid
Memory SW2-1	Reserved	-	Fixed
SW2-2	Auto Cutter	Invalid	Valid
SW2-3	Spool Print	Invalid	Valid
SW2-4	Full Col Print	LineFeed	WaitData
SW2-5	Resume aft PE	Next	Top
SW2-6	Paper width	80mm	58mm
SW2-7	Reserved	Fixed	-
SW2-8	PNE Sensor	Valid	Invalid

Memory SW3-1	Resum Ctrr Err	Valid	Invalid
SW3-2	Reserved	Fixed	-
SW3-3	Parallel 31 Pin	Valid	Invalid
SW3-4	Paper Select	Thermal	Black MK
SW3-5	Column Number	48/32 col	42/30 col
SW3-6	Reserved	Fixed	-
SW3-7	CBM1000 Mode	Invalid	Valid
SW3-8	Resum Open Err	Close	Command
Memory SW4-1	Auto Length	Invalid	Valid
SW4-2	BM Sensor	Surface	Back
SW4-3	Feed&Cut at TOF	Invalid	Valid
SW4-4	Reserved	Fixed	-
SW4-5	Reserved	Fixed	-
SW4-6	Reserved	Fixed	-
SW4-7	Reserved	Fixed	-
SW4-8	Partial only	Invalid	Valid
Memory SW5-1	Buzzer	Valid	Invalid
SW5-2	Reserved	Fixed	-
SW5-3	USB Mode	Virtual COM	Printer Class
SW5-4	Reserved	Fixed	-
SW5-5	Reserved	Fixed	-
SW5-6	Reserved	Fixed	-
SW5-7	Clear PNE LED	Auto	Set Paper
SW5-8	Reserved	Fixed	-

Switch No.	Setting	Default	Set Values
Memory SW7-1	Baud Rate	9600 bps	1200 bps, 2400 bps, 4800 bps, 9600 bps, 19200 bps, 38400 bps
SW7-2	Data Length	8bits	7bits, 8bits
SW7-3	Stop Bit	1bit	1bit, 2bits
SW7-4	Parity	NONE	NONE, EVEN, ODD
SW7-5	Flow Control	DTR/DSR	DTR/DSR, XON/XOFF
SW7-6	Reserved	-	
SW7-7	VCom Protocol	PC Setting	PC Setting, DTR/DSR, XON/XOFF
Memory SW8-1	Print Width	576 dots	
SW8-2	Paper Color	1 Color Normal	1 Color Normal, Color Normal
Memory SW9-1	Code Page	PC437	PC437/Katakana/PC850,858/PC860/PC863/PC865/PC852/PC866/PC857/WPC1252/PC864/Thai Code 18
Memory SW9-2	International Character	USA	USA, France, Germany, England, Denmark, Sweden, Italy, Spain, Japan, Norway, Denmark 2, Spain 2, Latin America, Korea, Croatia, China
Memory SW9-3*	Kanji	OFF	ON, OFF
SW9-4*	JIS/Shift JIS	JIS	JIS, Shift JIS
Memory SW10-1	Print Density	100%	70%, 75%, 80%, 85%, 90%, 95%, 100%, 105%, 110%, 115%, 120%, 125%, 130%, 135%, 140%
SW10-2	Print Speed	Level 9	Level 1, Level 2, Level 3, Level 4, Level 5, Level 6, Level 7, Level 8, Level 9
SW10-3	Reserved		
SW10-4	Reserved		

Manual Setting of Memory Switch (Memory SW)

The memory switch can be selected, changed, or written by the combination of three actions: pressing the FEED switch, pressing and holding the FEED switch, and opening or closing the paper cover.

1. Entering memory switch setting mode.

Set paper to the printer and keep the printer cover open. With the FEED button pressed and held, turn the printer power on, and then press the FEED button twice. Close the cover. If the current settings of the memory switch etc. are printed, the printer is now in the memory switch setting mode.

Memory SW (1) 00000000	0: OFF state 1: ON state
------------------------	-----------------------------

(No indication for 0/1 with memory switch ranging from 7 to 10)

2. Selecting memory switch

When the FEED button is pressed short (within 2 seconds), printing occurs in the order of "Memory SW1" → "Memory SW2" → "Memory SW3" → "Memory SW10" → "Save To Memory" → "Memory SW1" → repeatedly. When the memory switch you want to change is reached, press and hold the FEED button (for more than 2 seconds).

3. Selecting each switch item

2-8 items are provided for setting in each switch. By pressing and holding the FEED button long, the printer goes to the next item and prints the current setting of the item. Repeat pressing and holding till the item you want to change is reached.

Power ON Info (Valid)	OFF state: ERROR LED OFF ON state: ERROR LED ON
------------------------	--

(With memory switch ranging from 7 to 10, ERROR LED goes on only at the factory setting.)

4. Changing the setting

When the item you want to change is printed, press the FEED button short. The changed set value is printed. (When change of set value is repeated, the original set value is recovered). When you press the FEED button long, the set value is accepted and then the printer goes to the next setting item.

5. Returning to the memory switch select mode

When the setting of the desired content is completed, open the printer cover and then close the printer cover. This allows the printer to print the setting of the changed memory switch.

6. Saving the setting and exiting the memory switch setting mode

Press the FEED button short to move to “Save To Memory”. Then press and hold the FEED button. The printer prints the content of new setting and exits the memory switch setting mode to return to the normal standby state.

* Unless saving the setting is executed, the changed setting cannot be enabled.

7. Initializing the memory switch

When you want to return the memory switch setting to the initial state, go to “Save To Memory” in the above procedure. Here, open the printer cover and press and hold the FEED button till buzzer sounds. This allows the printer to return to the initial state.

* All the memory switches settings are returned to the factory set values.

5.3 Printing Paper

Use the print paper shown in the following table or the paper with equivalent quality.

Paper Type	Product Name
Recommended thermal paper roll	TF50KS-E2D from Nippon Paper KF50-HAD, PD150R, PD160R from Ohji Paper F220VP, HP220A, F230AA from Mitsubishi Paper

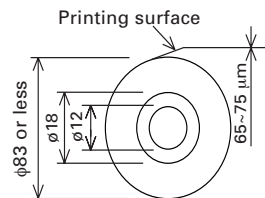
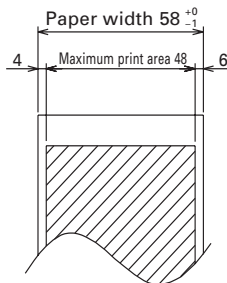
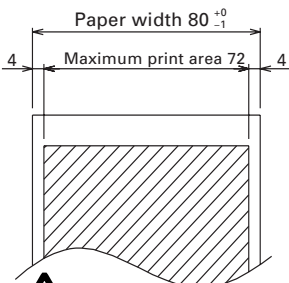

Unit: mm

CAUTION!

Use the paper with the start of winding to roll core is as shown below.

- No fold line is present and paper is along the inner diameter.
- No turnup is present.
- No pasting to core is present.
- Outer winding (print side out) is used.

CITIZEN SYSTEMS JAPAN CO., LTD.

6-1-12, Tanashi-cho, Nishi-Tokyo-shi Tokyo, 188-8511, Japan

Tel: +81 (0) 42 468 4608 Fax: +81 (0) 42 468 4996

<http://www.citizen-systems.co.jp>

TC74906-01F

1.01E-0707

Printed in Japan